

## 432 AND ABOVE EME NEWS March 2007 VOL 35 #3

EDITOR: AL KATZ, K2UYH; SCHOOL OF ENGINEERING, THE COLLEGE OF NEW JERSEY, PO BOX 7718 EWING, NJ 08628, TEL (W 609-584-8424) OR (H 609-443-3184), FAX (609-631-0177), E-MAIL [a.katz@icee.org](mailto:a.katz@icee.org)  
PROD/MAIL: BRIAN MULLANEY, KB2TIS/TOM KIRK, KA2VAD (609-584/8424), E-MAIL [mullaney@mccc.edu/kirkt@litech.com](mailto:mullaney@mccc.edu/kirkt@litech.com)  
NETNEWS EDITOR: G4RGK, DAVID DIBLEY, E-MAIL [g4rgk@btinternet.com](mailto:g4rgk@btinternet.com) (based on K1RQG's Netnotes and Reflector News) & CW LISTS  
EME NETS: 14.345, 10 AM ET SATURDAY AND SUNDAY (AFTER VARONET ENDS ON SUNDAY)  
NET CONTROL AND SKEDS COORDINATOR: JOE, K1RQG, TEL (207-469-3492), E-MAIL [k1rqg@aol.com](mailto:k1rqg@aol.com)  
EME DIRECTORY: <http://www.dl4eby.de/>, DL4EBY/DK0TU, KLAUS TIEDEMANN, TEL (49-30-7955467), E-MAIL: [tklaus@snafu.de](mailto:tklaus@snafu.de)  
NL EMAIL DISTRIBUTION and EMAIL LIST CORD: WARREN, W2WD [wbutler@comcast.net](mailto:wbutler@comcast.net) [TXT OR PDF OR "ON WEB" NOTICE]  
EME STANDINGS: DAN GAUTSCHI, HB9CRQ/HB9Q E-MAIL [hb9crq@hb9q.ch](mailto:hb9crq@hb9q.ch) OR SEE HIS WEBPAGE AT [www.hb9q.ch](http://www.hb9q.ch).  
THE NL WEB VERSION IS PRODUCED BY W6/PAOZN AND AVAILABLE AT <http://www.nitehawk.com/rasmit/em70cm.html>

**CONDITONS:** The next few months are jam packed with EME related activities. The JA Project BIG-DISH under the call 8N1EME is scheduled to start on the 24/25 Feb weekend on 1296 (and 144). 432 will be added the follow weekend, 2/3/4 March, and likely 5760 on 24 March – see the full schedule under 8N1EME below and more details in JH1KRC's report. The weekend of 24/25 Feb is also the first weekend of the European World Wide EME Contest sponsored by DUBUS/REF for Digital only operation – see the complete rules at the end of this newsletter (NL); there are some significant changes. The second weekend for operation on 432 and 5.7 GHz up on CW/SSB will be 24/25 March. There are also some major dxpeditions coming up. K0YW has announced that he has organized a 23/13 cm dxpedition to Hawaii (KH7X) for 19 to 24 April. See Bruce's report. Based this announcement, I have decided to move my own Hawaiian dxpedition, (planned with WY6G and N2UO for 15-19 June), from 23 to 70 cm. Hawaii has been on 432 EME several times in the past, but it has been a while. DL1YMK has also announced that his 2007 dxpedition will be to Iceland (TF/DL1YMK) starting on 13 May on 70, 23 and 13 cm – see Michael's report. The end of Jan/beginning of Feb yielded some activity. I have received many very positive reports on the EME SSB Contest. Conditions seemed excellent. There was a good burst of 432 activity during the following weekend for the 70 cm CW Activity Time Periods (ATPs), but 70 cm operation was reported lacking at other times. 23 cm produced reasonable activity and good conditions both weekend.

**EME SSB CONTEST - HIGH SCORES:** It looks like this year's fun event will be won by OK1CA who leads the field with 19x2x10 for 380 points. He is followed by OZ6OL with 16x2x11 for 352 points and IZ1BPN with 16x2x9 = 288 points. IA8LF had 270 points. VK3UM scored 110 points with no NA window due to winds. There are still some big signals as K5GW and DL0SHF that have not yet submitted their scores and could change the picture. The final scores will be in the next NL.



**OK1CA's 10 m dish used in the SSB Contest**

**8N1EME:** Project BIG-DISH <http://8n1eme.jp/> <<http://8n1eme.jp/>> schedule is as follows: 24 Feb on 1296 from 0300 to 0500, 0700 to 0900 and 1200 to 1400, 25 Feb on 1296 from 0400 to 0600, 0800 to 1000 and 1300 to 1500, 2 Mar on 432 from 0730 to 0900, 1100 to 1300, 1500 to 1700 and 1900 to 2015, and on

1296 from 0900 to 1100, 1300 to 1500 and 1700 to 1900, 3 Mar on 432 from 0830 to 1000, 1200 to 1400, 1600 to 1800 and 1900 to 2030, and on 1296 from 1000 to 1200, 1400 to 1600 and 1800 to 1900, 4 Mar on 432 from 0930 to 1100, 1300 to 1500 and 1900 to 2100, and on 1296 from 1100 to 1300 and 1600 to 1900, and 24 Mar on 5760 from 0015 to 1440.

**DF0MFG:** Sebastian (DG5CST) [vhf@freenet.de](mailto:vhf@freenet.de) writes about a new station on 23 cm EME in JO43hs -- DF0MFG is located on a Navy base. DL1LZG, [klonke@gmx.de](mailto:klonke@gmx.de), owns most of the station and will do much of the future operation as I am moving back to Bavaria. I will leave him my stuff (feed, preamps, TX line, etc.). He plans to move to a 3 m dish in the spring. We are presently running only a 1.8 m dish with OK1DFC septum feed and 200 W TWTAs. The transceiver is an ICC910H with no heater on XCO, and gives some frequency drift that can affect JT operation. In Jan we worked K2UYH (529/449) on CW and also on JT65C.

**DL1YMK:** Michael (&Monika) write that plans are in place for his 2007 Dxpediton to Iceland, TF/DL1YMK will be active on 70, 23 and 13 cm from HP84us -- We have tried to balance our operating times between the different bands and also allow some time for random work. The plan is as follows: First day Saturday 12 May, 23 cm, 0500 - 1000 1296.035 random, 1000 - 1400 1296.045 skeds, Sunday 13 May, 70 cm, 0500 - 1200 432.035 random, 1200 - 1600 432.045 skeds; 14 May 0500 - 1800 432.045 skeds; 15 May 0500 - 1900 1296.045 skeds; 16 May 0600 - 2000 1296.045 skeds; 17 May 0700 - 2200 TX/RX 2320.045/RX 2304.045 skeds; 18 May 0700 - 2000 TX/RX 2320.045/RX 2304.045 skeds; 19 May 0000 - 2359 23 cm DUBUS contest random only; 20 May 0000 - 2359 23 cm DUBUS contest random only; and 21 to 24 May open to everything (including JT65). We may be QRV via the Internet with email access. We will look on the random frequencies after a sked is completed, but we kindly ask people to keep the sked frequencies clear. We learned in CT3 that we lost some potential QSOs with weak stations because of big stations taking over the sked frequency. Tailending is absolutely no problem, if done on the random frequency. I hope to increase our efficiency by this procedure. If there is no interest in skeds during a designated sked slot, we automatically will tune on the random frequencies (which is 10 kHz below the sked frequency). Many thanks in advance for your reliable assistance. Regarding our home station, unfortunately my repair activities have slowed down, as my father sadly passed away on 6 Feb at the age of 83. Its unbelievable how many formal things need to be coped with now. Well, I still have my mother and hope to have her for some time still. [The condolences of the EME community go to Michael].

**DL4MEA:** Guenter [guenter.koellner@siemens.com](mailto:guenter.koellner@siemens.com) writes – I have expanded my dish to 4.5 m and will be QRV on both 1296 and 2300. I first repaired my 13 cm PA. (I simply replaced the piece of PCB which arced-through with two parallel pieces of 50 ohm semi rigid). I put it back in the box behind the dish, and was not surprised that my echoes were much better. I was able to even copy my SSB echoes nicely without filtering. Unfortunately, the activity was on 23 cm this weekend because of the SSB contest. I then had to repair my 23 cm transverter, which needed two bad transistors replaced. I immediately heard on SSB ON7UN (42), K9SLQ (52), DL0SHF (53) and LA8LF (42). While optimizing the 2nd stage preamp for optimum NF my wife came into the shack and asked for a lift to the hospital. The reason? We now have a son, his name is Stefan. He was born on 27 Jan 1215! After a short break while waiting for the rest of the family to arrive, I listen to the moon again and there were nice signals from K5JL (57) and again K9SLQ (57). TX on 23 cm will follow soon. If somebody would like to run on 13 cm, please let me know. On 13 cm I have a Super VE4MA feed, HEMT-Preamp, DB6NT-Transverter and a 2 x MRF21120 PA driven by a single MRF21120. On 23 cm I have a diagonal waveguide feed, ATF35076 cavity preamp, and DD9DU transverter – PA yet.

**DL7AFB:** Bodo [Bodo.Woyde@web.de](mailto:Bodo.Woyde@web.de) sends news on his EME activity -- Within the last 6 weeks I greatly improved my 70 cm station and made some

nice QSOs with both CW and JT. In my eyes JT is a fantastic mode, making it comfortable to work stations at the edge of perceptibility, in particular for small stations with 4 x 22 yagi and 700 W like me. More over, I think JT will not be the end of the evolution in digital communication. I believe we will see some new and even more powerful digital modes soon that will allow single yagi EME operation on both ends. I can say each of my EME contact makes me happy regardless the mode. And as you see I worked a lot of stations with my small set up. By the end of Dec I QSO'd SM3JQU (O/O) on CW with his 4 x 32 el yagis, PA3CSG (O/O) on CW, OZ4MM (O/O) on CW, EA3DXU (16dB/20dB) on JT65b and OK1DFC (13db/O). The New Year started very well with a new continent, when I worked ZS6WAB (23dB/22dB) who was using just 160 W into a 5 m dish, on Jan, 7th I completed random QSOs with K3MF (O/O-JT:-25/? ) and G3LTF (559/449-CW). On 27 Jan I had a partial with UT3LL in JT-mode (22dB/? ) - after sending reports decoding failed on both ends while traces remained bright on my screen(?). After that I worked UA3PTW (559/549) on CW and DF4UE (23/20) on JT - he also has just 4 yagis. On 28 Jan I tested with JA6AHB with the moon blocked by trees without any success on both ends. I did work after several attempts W7AMI (24dB/23dB), who uses 4x33 FO yagis. The same night I also worked OZ6OL (O/O) on CW. I QSO'd on 1 Feb DK3SE (26dB/25dB) who uses 4x21 yagis, and on 2 Feb S53RM (22dB/22dB) on JT who uses 8x26 el yagis and 700 W. During this last QSO the moon was behind the top of a single pine tree and confirmed my assumption that the attenuation of tree tops is about 5 to 10 dB each. But as the symmetric signal strength indicates, there seems to be an additional noise emitted by the obstacle. After the test I worked EA3DXU again with his great signal (17dB/24dB) on JT. On 3 Feb I tested with SV1BTR, who produced nice (559) signals in speaker quality, but unfortunately didn't copy me. During the DUBUS ATP I did not have much luck because by the start time, the Moon was already behind the trees. Nevertheless, I worked OZ4MM (559/549) and heard SM2CEW, SV1BTR and UA3PTW on CW. I'm going to improve my RIW PA by replacing the 4CX250s with Svetlana GS-36Bs (4CX400s). If someone has experience with this change, I would appreciate hearing from them. In addition to radio operation and station improvements, I've have created a web-page showing some details of my EME-station and other ham related stuff at <http://www.dl7afb.homepage.t-online.de/eme/eme.htm>.

**DL7APV:** Bernd [dl7apv@t-online.de](mailto:dl7apv@t-online.de) was QRV during the DUBUS 70 cm CW ATP in Feb and QSO'd UA3PTW, S53RM, OZ4MM, OZ6OL, KE7NR on JT65, SV1BTR and NC1I with a tremendous signal. Also heard were G3LTF, VK4AFL, SM3BYA and SM2CEW. Bernd notes that he needs Hawaii on 70 cm EME.

**F5JWF:** Phil [f5jwf@wanadoo.fr](mailto:f5jwf@wanadoo.fr) reports on his Jan EME efforts -- I was active on 26/27 Jan on 23 cm. This was my first trial with my brand new station and I was surprised that on my first key down, I could hear my echoes about 8 dB above the noise. I was using an LDMOS PA which about 130 W. I plan to add a few more of these devices in parallel to get some more power. I used the same 12' solid dish with HB tracking that I use for 3 cm. The feed is based on OK1DFC's septum design. I worked on CW LA8LF, LA9NEA, ON7UN, OK1CA, LX1DB, K5JL, ES5PC, RW1AW, IK3COJ and G3LTF. I also contacted a few stations on JT65C, ES5PC, ES6RQ, SM5LE and JA6AHB. All were of course initials. I now to spend some time getting this system waterproofed, specifically the 26 V power supply that was only temporarily installed at the antenna. I planned to be on for the upcoming EME contests.

**G3LTF:** Peter [g3lft@btinternet.com](mailto:g3lft@btinternet.com) made it through the BIG winds and was QRV off the moon in Jan/Feb - I've been active on 3 bands in this period and the dish survived the strongest winds we have experienced in 11 years (well over 80 mph). I was only able to be active for a short time in the 1296 SSB Contest on 27 Jan, from 1215 to 1430. Conditions were excellent and there was quite a bit of activity. I worked 9 stations on SSB, OZ6OL, VK3UM, VK4AFL, OH2DG, LA8LF, OK1CA, ON7UN, LX1DB and DL0SHF. I heard SM4DHN working stations, but never found him calling CQ. On CW I worked SM5LE. The next day on 28 Jan I worked VK4TL, VK4AFL, IK3COJ, RW1AW, GW3XYW and F5JWF for initial #251, who has a nice signal and should be workable by many stations. On 1 Feb I worked DL4MEA on 2320.100 on both CW and SSB. Guenter has enlarged his dish to 4.5 m. On 4 Feb I was on for the 432 CW ATP. Conditions were good despite there being a near apogee moon. I worked SM2CEW, UA3PTW, SV1BTR, NC1I, OZ4MM, OZ6OL and K2UYH, and heard UT2EG. It was disappointing to only find two US stations QRV in the middle of the NA window. Finally at moonrise on 4 Feb I looked for VK4AFL on 1296, but the tree attenuation was too much and I couldn't even find my echoes. However later on when the moon cleared the trees, I worked JA6AHB (569).

**IK3COJ:** Aldo has a new e-mail address [ik3coj@fastwebnet.it](mailto:ik3coj@fastwebnet.it) and was QRV in the SSB EME Contest. He QSO'd on SSB on 27 Feb at 1414 DL0SHF (54/33) JO54, 1429 LX1DB (56/55) JN39, 1437 OK1CA (53/54) JO70, 1952 K9SLQ

(54/52) EN70, 2042 K5JL (55/55) EM15, 2052 IZ1BPN (53/54) JN35 and 2146 K2UYH (53/559) FN20 on SSB to CW) for a score  $(6x2+1)x5 = 65$ . Aldo also worked on 28 Feb F5JWF on CW for initial #121.

**IZ1BPN:** Steve [iz1bpn@libero.it](mailto:iz1bpn@libero.it) reports that his group was QRV on 1296 for the first time during the SSB Contest -- We were very pleased to not miss the opportunity for "fun" in the great 1296 SSB event. We have been working to put our 8 m dish on the moon. The station was still "a work in progress" at the start of the contest. We were still testing our new TH308 PA. During this testing with the antenna already tracking the Moon, we were able to listen from outside the house through an open window to some very strong signal on SSB off the Moon. By 1600 we were ready to start operating and continued to 2400 with a couple of hours break for dinner - (a must since our families found us at the station house). The current setup is an 8 m dish (0.4 f/d) with VE4MA choke ring feed, FHX35 + MGA62563 dual stage LNA (0.45 dB NF & 37 dB gain), DB6NT XVTR and TS850S plus 2C29 driver (indoor) and TH308 PA at the tower. We are planning also to try soon a Septum feed made by OK1DFC. In the contest there were some rally impressive signals (LX1DB, OK1CA, W9SLQ, K2UYH and others) but poor activity from little stations. Possibly they are not confident on CW/SSB mixed mode QSOs? This was a lost opportunity because we were able to make SSB/SSB QSO with station down to 3.5 mdish. We calling CQ on SSB for a while and didn't listen for CW signals from small stations. Sorry for guys that may have called us without having a reply from our side. QSO'd were LA8LF (54/56) JO, LA9NEA (55/55) JO, ON7UN (57/55) JO, GW3XYW (44/44) IO, OK1CA (55/55) JO, K9SLQ (57/56) EN, OZ6OL (44/54) JO, K5GW (55/55) EM, VE6TA (54/55) DO, DL0SHF 55/55) JO, K2UYH (55/54) FN, K5JL (55/56) EM, W7BBM (54/55) DM, IK3COJ (53/54) JN, LX1DB (56/56) JN and WA6PY (53/54) DM for a score of  $16x2x9 = 288$  points. Operators were IK1MTZ, IK1WYB, IK1EGC, IW1AZJ and IZ1BPN. Anyway we found this contest simply great!



**IZ1BPN 8 m dish using for the fist time in the SSB Contest**

**JH1KRC:** Mike [jh1krc@syd.odn.ne.jp](mailto:jh1krc@syd.odn.ne.jp) sends news of the special EME operation from QM06 in Japan -- KDDI, one of the Japanese telecommunication services companies, has agreed to support Project BIG-DISH, composed of some 40 Japanese moon bouncers, and JARL. We will use the antenna IBA-4, which is the 4th antenna of Ibaraki Satellite Communications Center, KDDI Corporation, for experimental moonbounce operation on 144, 432, 1296 and 5760 (license not yet received). IBA-4 is a 32 m Cassegrain dish made by Mitsubishi Electric Corporation in the 1980s. It is fully rotatable with elevation possible up to 90 degrees and has automatic moon tracking. The largest problem we have is that we cannot remove the sub-reflector, which is 2.9 m in diameter and about 9 m in front of the main reflector. Therefore we have to use this sub-reflector in some way for EME operation. We are still waiting for our high power EME license and permission for 5760 MHz moonbounce transmission from the ministry. The bands other than 5.7 GHz are sure to be licensed for

operation with 500 W output. We will use the callsign 8N1EME. Operation is planned on CW, SSB, and JT65 (TX 1<sup>st</sup> period) especially on 144 and possibly on 432. Fundamentally, we think that random QSOs are best, although some scheduled QSOs may be considered in special cases. The antenna will be vertically polarized on 144 and 432 (TX 432.030 and RX 432.050), and circular pol on 1296 (1296.010) and 5760. Operation is planned for late Feb and early March. QSL via JH6RTO. Further details will be announced on our web site at <http://8n1eme.jp> <<http://8n1eme.jp>>. Be prepared and don't miss this historic moonbounce operation from this very special place!

**K0YW:** Bruce, [k0yw@frontier.net](mailto:k0yw@frontier.net) has announced a major expedition to Hawaii for 23 and 13 cm in April. He has the assistance and support of KH6ND, KH6YY, KH7U and K2PF, plus the generous help of K5GW, W5LUA, WA5WCP, K5JL, WD5AGO and K1RQG. Operation will be on the island of Oahu from 19 to 24 April at the beautiful Contest station of KH6YY on the mountains overlooking Kaneohe Bay using the OAHU Contest Group's call, KH7X. The 23 cm system will consist of a Modified 12' TVRO dish with round waveguide septum feed, WD5AGO pre-amp, FT-736 exciter driving a GS-15B amplifier at 350-400 W out. The antenna will be auto tracked via US digital absolute encoders. The antenna will be located with a clear shot nearly to the horizon on for both moonrise and sets. Operations will be primarily CW with some excursions to SSB for big stations. There are No plans to operate any JT modes. Skeds operations will be accepted. Their configuration and coordination will be defined in a following bulletin. QSL manager will be K2PF. There is a parallel operation also well into the planning stages for operation on 13 cm. More info will follow.

**K5SO:** Joe [k5so@valornet.com](mailto:k5so@valornet.com) is still concentrating on 432 Pulsar work and getting some great help from K1JT in form of supporting software programs to provide frequency information of existing Pulsars as they changes. One needs to determine Doppler accurately in order to track pulsars. The info will be available to anyone interested. Joe is looking for a good frequency standard, either Rubidium or Caesium. He needs 1 part in 10 to the 12th.

**KL6M:** Mike [kl6m@qsl.net](mailto:kl6m@qsl.net) reports high winds thwarted his SSB Contest EME weekend plans, but Mike was active during the Feb AW – We have had warm WX here (got up to 52 F), but lots of high wind has unfortunately been keeping me off the moon. I managed to get on and had great fun during the Feb AW. The ATP was useless to me as the moon too low here. I heard and worked only one station on 432, I5CTE (549/549). On 23 cm I had my first SSB QSO with K9SLQ. His signal was absolutely amazing! He was (599) on CW and (58) on SSB - arm-chair copy! During the following week I worked N0OY (579/559). On 1296 I'm still running only the 2 x 2C39 PA with probably about 100 W at the feed.

**LA8LF:** Anders [anders@LA8LF.com](mailto:anders@LA8LF.com) was active during the SSB contest time period on 23 cm — On 27 Jan I made 4 initials on CW with VK4TL, F5JWF, G4RGK and IZ1BPN to bring me to #188. Conditions were good on moonrise and excellent on moonset. I also worked on CW VK4AFL, SM5LE, VA7MM and WA6PY. On SSB I worked 15 stations: VK3UM, G3LTF, ON7UN, LX1DB, SM4DHN, OK1CA, IZ1BPN, DL0SHF, K9SLQ, OZ6OL, K5JL, K2UYH, VE6TA, K5GW and WA6PY for a contest total of 15x2x9 = 270 points. Heard were JA6AHB and IK3COJ on CW. My 1500 W HPA is working nicely all the time, but I lack an EL encoder for my VK3UM tracking system. I need to finish my VE1ALQ/F1EHN tracker and install the US Digital encoders. Installing my new NEC, 700 kg, solid dish last summer/fall took quite some energy and I feel a bit empty at the moment.

**LX1DB:** Willy [wbauer@pt.lu](mailto:wbauer@pt.lu) was on for the SSB EME Contest and made 12 QSOs. His big dish can only go up to 60 degrees, so his moon time is limited on the high dec weekends as was the case during the contest. He worked VK3UM with (57/57) reports, but missed VK4AFL. During the Feb AW he was on 13 cm testing a new 450 W PA, but only QSO'd F2TU. Conditions were not very good with bad QSB.

**N0OY:** Pete (x-WB0DRL) [petesias@yahoo.com](mailto:petesias@yahoo.com) writes that this is his new call – I got the old 28' (WB0DRL) dish going again on 23 cm with a Septum feed and 300 W at it. I will be installing automatic tracking in the next few weeks. I was on testing things and noticed that there is activity during the week – hi.

**N2UO:** Marc [lu6dw@yahoo.com](mailto:lu6dw@yahoo.com) writes -- I was not recently active on 1296 EME because we are moving to Greensboro, North Carolina, late in February. The new QTH is in FM06 (same as K4QI), and about 500 miles from here. My email address, which I have been using since 1995, will remain the same. I plan to be back on EME pretty soon. I removed my 3 m stressed parabolic reflector from the tripod, and it seems to hold together very well, even after cutting the strings that give it its shape. Maybe it is now 0.55 f/d instead of 0.45. In any case, the reflector weighs only 20 kilos or so, and can be easily

handled by one person. The tripod has casters and can be pushed around. It will take a day or so to put everything back together. On another topic, I am doing the 2006 ARRL EME contest write up this year. I have received the ARRL database, and I was pleased to see that the logs have been crosschecked and reviewed for integrity. The assisted operation class was also carefully verified. So far, I can report that the level of activity was about the same as last year. The ARRL has a new Contest Manager (Tom Hogerty), and he has done a great job.

**NCII:** Frank [frankp@gcq.net](mailto:frankp@gcq.net) was active for the Feb 70 cm CW ATP -- The following stations were worked during the 4 Feb ATP at 0410 SV1BTR (579/569), 0418 K3MF (549/559), 0426 OZ6OL (569/569), 0439 UT2EG (569/569), 0446 OZ4MM (579/579), 0459 G3LTF (579/579), 0519 SM2CEW (569/579) - I changed Peter's report to 579 after I corrected my receive polarity, 0548 DL7APV (I believe it has been MANY years since my last QSO with Bernd) and 0602 K2UYH (55/55) - solid SSB signals. I started listening and calling CQ at around 0330 but nothing was heard until 0400 and then suddenly several stations popped up. It seemed like everybody waited for 0400 as if it was the start of a contest. At 0600 everyone disappeared. I continued to call CQ up until 0640, but unfortunately there were no takers. Conditions were fine, but not as good as the previous night or the previous weekend when there was virtually no activity. Starting at 0100 on 3 Feb I called CQ for 2 hours and have heard nothing but my own echoes were blasting in. The previous weekend, I called CQ for 6-7 hours but only worked FR5DN. Phil had an outstanding signal. I'm trying to get on EME as much as possible to generate more activity, but so far results have not been good. After April 1st I will have little or no time for ham radio until late Oct.

**OE5MPL:** Peter [oe5mpl@aon.at](mailto:oe5mpl@aon.at) is a relatively new 70 cm EME station that operates from a ham location in JN78cj away from his home QTH. He runs ~500 W on 70 cm to a 4 x 21 el yagis array. Because of his second QTH, his sked time has been limited, but he has been active in the contests.

**OK1CA:** Franta [ok1ca@ges.cz](mailto:ok1ca@ges.cz) sends his EME SSB Contest results -- I worked on my preamplifier and now measure sun noise at 21.5 dB (SF80) and moon noise at 0.7 dB. During SSB contest I made 19 two way SSB QSOs with VK3UM, OZ6OL, RW1AW, ON7UN, SM4DHN, G3LTF, LX1DB, DL0SHF, OH2DG, LA8LF, IK3COJ, IZ1BPN also initial #172, K9SLQ, GW3XYW, K5GW, K2DH, K5JL, VE6TA and K2UYH. These gave me a score of 19x2x10 for 380 points. I also worked on CW VK4AFL, F5JWF #171 and SM5LE. The EME signals were very good even with real winter weather - snow and strong winds.

**OK1DFC:** Znedek [ok1dfc@seznam.cz](mailto:ok1dfc@seznam.cz) is not QRV on the moon while he works on fixing his dish after the big wind storm, but was QRV via the eye ball -- I have had business trip to UA, and courtesy of RW3BP the opportunity to visit him and participate in very nice mini EME meeting – see picture below. Sergey is very hard work on 76 GHz EME and is looking for a TWT. I continue to repair gears and expect to be QRV again soon.

**OZ4MM:** Sig [vestergaard@os.dk](mailto:vestergaard@os.dk) reports on his recent activity -- I was able to be QRV in both Feb 432 CW ATP windows. I found good activity and conditions, despite the fact that I was only able to TX in H-pol, as I had a very high return loss in the V-pol. I think this is probably due to water in the V-feed. I worked the following stations during my 2 hours of operation: UA3PTW, VK4AFL, SM3BYA, DF3RU, UT2EG, DL7APV, NCII, OZ6OL, SM2CEW, G3LTF, DL7AFB, SV1BTR and K2UYH. Heard was EA3DXU (449). Most stations were (559) or more.

**OZ6OL:** Hans [oz6ol@mail.dk](mailto:oz6ol@mail.dk) was active in the 23 cm SSB Contest and reports – I QSO'd on 27 Jan at 1038 VK3UM (54/54) QF22, 1044 OK1CA (54/54) JO70, 1102 RW1AW (55/56) KP50, 1217 G3LTF (55/44) IO91, 1250 LX1DB (56/56) JN39, 1402 ON7UN (55/55) JO21, 1409 DL0SHF (55/5) JO54, 1800 GW3XYW (54/44) IO71, 1831 K9SLQ (56/55) EN70, 1934 IZ1BPN (54/44) JN34, 1940 OH2DG (54/43) KP30, 1957 VE6TA (55/44) DO33, 2006 LA8LF (54/44) JO59, 2036 K5JL (56/55) EM15, 2047 K2UYH (55/55) FN20 and 2122 W7BBM (54/55) DM42. My score was 16x2x11 for 352 points with a 5 m dish, 250 W at feed and homebrew rig (new audio on TX with RF SSB compression).

**PA3FXB:** Jan [jvmap@bart.nl](mailto:jvmap@bart.nl) is QRV on 23 cm EME with a 3 m dish and 150 W, but is also involved with a group restoring a 25 m dish at Dwingeloo. Un to now he has worked only JT, but in Feb he made his first CW QSO with K2UYH and is interested in trying more CW as well as JT. Jan listened during the SSB Contest and was surprised to copy 3 SSB stations (K9SLQ, LX1DB and K2UYH)! He says "Weak SSB from the moon is a different world... Difficult to tune in, but very clearly present. It is unbelievable that a signal that "feels" so strong is so difficult to copy. It was a thrilling experience to here voices from the moon!!!

**SM2BYA:** Gudmund [gudmund.wannberg@telia.com](mailto:gudmund.wannberg@telia.com) writes – I arranged to stop at my farm during the Feb skeds weekend for some R&R (rest and radio) on my way home from meetings in Stockholm. Checking the 432 system, I noticed that the RX gain was way down and sun noise yielded only 7 to 8 dB - should be ~ 12 dB. I climbed the tower and checked all coax connectors and bias voltages. All was OK, but there was some moisture in the preamp box and traces of corrosion on the preamp casing. This was the first time that I've seen water in that box since it went in some 15 years ago. Everything pointed to either the preamp or 2<sup>nd</sup> stage being bad but not dead. I decided to give the moon a try anyway. I was able to find my echoes much weaker than normal. The system was clearly badly degraded. Nevertheless, I worked UA3PTW and OZ4MM. And as I was getting ready to switch off, UT2EG for our first 100% QSO and a new initial! I will have the preamps fixed for the DUBUS contest in March.

**SV1BTR:** Dimitris [jimmyv@hol.gr](mailto:jimmyv@hol.gr) reports on his new 70 cm array -- I wanted to report that SV1BTR is operational with a new array for 70 cm. The array is now xpol. I kept my old 8 x 26 el 8.5 wl yagis for H pol and added 8 x 20 el 6 wl yagis for V pol. The V pol yagis have 1.5 db less antenna gain, but sun noise is excellent. However, sun noise on H pol is down compared to the past due to the very close proximity of H and V elements. [Dimitris was QRV during the Feb 70 cm ATP with a superb signal].

**UT3LL:** Valery [ut3ll@kharkov.com](mailto:ut3ll@kharkov.com) is active on both 70 and 23 cm – In Feb I worked on 70 cm JA6AHB and EA3DXU (21dB) on JT65b. My main problem for skeds is moon blockage by a high rise building between 225 and 275 degrees AZ. He is presently working on an improved station for 1296.

**UZ5DZ:** Vlad [uz5dz@mail.ru](mailto:uz5dz@mail.ru) is temporarily off 70 cm EME while he builds a permanent antenna. He was active during the ARRL EME Contest with 8 x 18 el yagis, a GS35 PA and MGF 1302 preamp. My first QSOs on EME were with VK3UM, NC2I, OH9PO and DL9KR. I expect to be QRV again soon.

**VA7MM:** Mark [lunarlink@hotmail.com](mailto:lunarlink@hotmail.com) sends a note on his group's (VE7CMK and VE7CNF) activity for the newsletter -- We operated briefly in the 1296 EME SSB Contest and claim one contest contact with K2UYH. We also tried working ON7UN who had a very good SSB signal, but we did not complete. Two-way CW QSOs were completed with K5JL, WA6PY, LA8LF, IZ1BPN and K9SLQ. I am looking ahead to operating next in the DUBUS Digital EME Contest on 24/25 Feb.

**VE4MA:** Barry [ve4ma@shaw.ca](mailto:ve4ma@shaw.ca) is making progress getting back on 23 cm EME -- I had fun so to speak during the SSB contest. I planned to finish up my 2 tube amp and get on, but had a problem with low output and popped a tube - #@%\*! So I decided that since the signals were so good I would get on with my 75 W DEMI driver. I hooked it up only to find the output low and only about 20 W. One module was dead! So I listened most of the day, from 2100 through 0200. There were great signals from K9SLQ, K2UYH, K5JL, ON7UN, LX1DB and others with excellent signals on SSB. SLQ was better than Jay, probably by 3 dB. It was hard to compare to LX1DB since Willi was only on SSB. Using the panadapter on the SDR sure is great on EME. There were also many signals on CW including LA8LF and WA6PY. I was surprised that the ON7 had trouble picking out callers that I could hear.

**VE6TA:** Grant [ve6ta@telusplanet.net](mailto:ve6ta@telusplanet.net) was active on 27 Feb during the 23 cm SSB contest and worked 11 stations. He made no Asian contacts, but did connect with KL6M and VK4AFL. He added on 3 Feb on 23 cm K9SLQ, WA5WCP and WW2R, and heard K5JL and WB2BYP, and on 4 Feb NOOY.

**VK3UM:** Doug [tikaluna@bigpond.com](mailto:tikaluna@bigpond.com) writes on his Feb activity -- It is the 3rd month in a row that I have had gale force winds during my US windows. I thus missed making any NA QSO during the SSB contest. I did log 11 Eur QSOs and worked the following: OK1CA (54/55), OZ6OL (54/54), RW1AW (57/57), VK4AFL (53/43), G3LTF (54/54), OH4DG (53/33), LA9NEA (54/55), LA8LF (55/55), ON7UN (56/56), LX1DB (57/57) and SM4DHN (56/56) at 1 degree elevation! It was great to hear many of the familiar voices again. I ended with a score of 11x2x5 = 110 points. Why do we bother with CW when you can chat like this! I feel calling CQ on CW and then switching to SSB is like using a logger. It does not seem fair! It should be 10 points for SSB to SSB initiated contacts and 1 for the 'logger mode'. I worked all SSB initiated QSOs - no DS.

**VK4AFL:** Trevor [thenton@bigpond.net.au](mailto:thenton@bigpond.net.au) reports the 1296 SSB Contest was a lot of fun -- I worked VK3UM, G3LTF, RW1AW and K9SLQ with a huge signal. On CW I worked OK1CA, RW1AW, LA8LF, VE6TA, K9SLQ, KL6M, IK3COJ, LA9NEA, OE5JFL, JA6AHB and G3LTF. 432 contacts were made with OZ4MM, DF3RU, OZ6OL, SV1BTR and UA3PTW. During the Feb skeds weekend I added OE5JFL and JA6AHB on 23 cm and then went to 70 cm for part of the CW ATP OZ4MM, DF3RU and OZ6OL. Conditions on 70 cm at this time were exceptional - polarity was very sharp, which is always a good sign.

Overall the last few weeks have been quite productive with a reasonable amount of activity especially from Europe.



Comet passing VK3UM's dish!

**WA6PY:** Paul [pchominski@maxlinear.com](mailto:pchominski@maxlinear.com) had very busy year end and beginning of this year -- I was on 1296 for the SSB EME Contest on 27 Jan and QSO'd on CW K5JL, LA8LF, VA7MM and IZ1BPN, and then on SSB LX1DB (56/56), K2UYH (55/54), IZ1BPN (44/53), LA8LF (55/54) and VE6TA (44/44) for a total of 5 QSOs in 4 sectors and 40 points. On 18 Jan I called CQ and someone very weak called me, but I needed a few more sequences to get the callsign. Then K5JL called me and told that KL6M was calling me. After QSOing K5JL, I called KL6M. Mike was quite good copy. He was about 100 Hz below K5JL and the other weak station was about 350 Hz below. After KL6M I called again QRZ, but did not hear this other station. I should be able to QSO him, but I need a few more sequences to copy. Please remember that I have only a 3.6 m dish with f/D=0.36 that is under illuminated with my W2IMU horn. [Note that Paul has a new e-mail address].

**WW2R:** Dave [ww2r\\_eme@g4fre.com](mailto:ww2r_eme@g4fre.com) reports on his Jan activity -- On 27 Jan in the SSB Contest I CWNR K5JL, LX1DB and IZ1BWN all on SSB. I also CWNR IZ1BWN on CW. I decided the SSB contest is not fun for 10' dish owners – (I was very discouraged but encouraged by later CW contacts). So I looked up the band and found and worked GW3XYW on JT65C (16dB) for initial #56\* and then on CW. This contact was followed by ES6RQ (14dB) on JT65C #57 and then on CW (CW initial #50). I also worked UR5LX (24dB) on JT65C. On Jan 28 I added K9SLQ and K5JL on CW, PA3FXB (26 dB) on JT65C #59\* and W5LUA (9dB) on JT65C (this was my "worst DX" of 4 miles!). On 30 Jan I worked W5LUA on JT65C again trying to resolve some WSJT interpretation issues. I have now reached my target of 50 CW initials on 1296 and plan to move on to other projects. [Copies of Dave's talk on "Backyard EME" can be found on the web at <http://g4fre.com/ementms.pdf>].

**K2UYH:** I [a.katz@ieee.org](mailto:a.katz@ieee.org) had some good results during the end of Jan and the beginning of Feb. I QSO'd on 1296 on 24 Jan at 1715 DF0MFG (21dB/O) on JT65C for initial #287\* followed by a CW QSO (549/555) #257 and on 26 Jan at 2235 PA3FXB (17dB/O) on JT65C #288\* and 2311 W7UFP (559/559) on CW, in the SSB contest on 27 Jan at 1937 DL0SHF (56/55) JO, 1948 OK1CA (55/55) JO, 2000 K9SLQ (57/56) EN, 2010 IZ1BPN (55/54) JN #288\* and #258 on CW/SSB, 2025 LA8LF (55/55) JO, 2037 K5JL (56/57) EM, 2040 VE6TA (56/56) DO, 2045 LX1DB (57/57) JN, 2047 OZ6OL (55/55) JO, 2100 W7BBM (57/56) DM, 2115 K5GW (57/57) EM, 2136 GW3XYW (559/-) lost, 2147 IK3COJ (549/53) JN, 2237 WA6PY (54/55) DN and 2252 VA7MM (559/43) CN on SSB to CW for a score of (13x2+1)8 = 216 points, on 28 Jan at 2230 PA3FXB (449/529) on CW for #259, and on 4 Feb during the CW ATP 0540 G3LTF (559/559), 0546 OZ4MM (569/559), 0553 SV1BTR (569/559) and 0603 NC1I (55/55) on SSB. I also had some not so good results. JT skeds on 432 with SP6GWB, UT3LL (WX problems) and WA8RJF yielded nil results. I plan to QRV in the Eur Digi EME Contest and will try calling CQ on .048 on both 70 and 23 cm.

**NETNOTES BY G4RKG: K0RZ** is interested in 70 cm activity from HI as it is one 5 states (HI, VT, KY, ND and NV) he still needs for WAS. **W16M** in San Diego has a 10' dish with .25 f/d and is getting interested in EME. Rod's e-mail is [w16m@amsat.org](mailto:w16m@amsat.org). **JK1KTY** is QRV on 432 EME with 8 x 25 el and 50 W. He is looking for sked partners. [Does anyone have an e-mail address for him?] **DK3SE** is attempting 1296 EME. Salvo is using 4 x 35 el F9FT yagis and a reasonable amount of power using JT65C. **K0WLU** is interested in 23 cm EME. He has a 12' dish and is refurbishing it for EME use. **W7MEM** has his preamp repaired and is back on 70 cm EME. He worked HB9Q on JT, but is also

available on CW. **WB0GGM** is temporarily home and walking with a cane, but has to go back to the hospital for more therapy. **K5JL** was on 23 cm in Feb and worked WA5WCP, WW2R, WB2BYP and VE6TA. **WB2BYP** in Feb QSO'd on 1296 K5JL and heard bits from WW2R and WA5WCP. He also copied K9SLQ. **SM4IVE** is QRV again on 70 cm with a yagis array. **WA5WCP** now has 3 dB more power on 23 cm. During Feb he had contacts with VE6TA and K5JL, but did not complete with WB2BYP. **W5LUA** reports working DL4MEA on 13 cm and on 23 cm NOOY [x-WB0DRL] with nice signal during Feb. **K7XC** is active on 432 and 220 moonrise and looking for skeds (especially on 220). **F1PYR** is putting up a 3.5 m dish and plans to be active on 23 cm and up. **G4RGK** worked ES5PC on 23 cm and a couple on 70 cm during the Feb AW/ATP. **SM2CEW** was on 70 cm and had a good time during the west ATP. Peter heard great signals from K2UYH and NC1I. On 4 Feb he could not make his K7XC sked.

**FOR SALE: N2IQ** has the following items for sale: OE9PMJ 23 cm cavity PA built by K2AH, unused. Thompson TH338 tube with water jacket (23 cm higher power version of TH328). High Power 70 cm amplifier and power supply custom built by K2AH using Thompson TH347 tube (3 KW+!) with spare TH347. Pricing and pictures are available from Mark at [mark@nationalaudio.us](mailto:mark@nationalaudio.us). **G4RGK** is looking for a couple BFQ68 devices to revive an old 23 cm amp. **K0WLU** is looking for a 12' or larger dish in the midwest area.

**TECHNICAL: Temperature compensated Bias for MESFETs** -- WA6PY sends the following discuss: GaAs transistors as MESFET, HEMT and PHEMT devices have a relatively big variation of the gate bias voltage even in near constant temperature conditions. Using a source resistor for generating negative voltage for gate bias is not a very good solution as the parasitic impedance of the network between source and ground can cause stability problems. Most of these transistors have very high  $f$  and I've seen oscillations above 20 GHz. Such oscillations are sometimes difficult to detect, but can deteriorate the NF of the amplifier. A commonly used circuit that places an extra PNP transistor in the gate bias feedback path is very efficient, but requires many additional components. This circuit when properly designed does take care of temperature variations of  $I_d$  versus  $V_{gs}$ , and is often used in high volume production. I have been using for many years a very simple circuit that requires only the addition of a feedback resistor from drain to the gate. This circuit is also very efficient. I made measurements of two LNAs using FHX35LG and MGF1304a devices that show good performance over the temperature range from  $-25^\circ\text{C}$  to  $80^\circ\text{C}$ . First, the circuit without any bias stabilization was measured. It appeared that even this circuit did not perform very badly. Some help comes from the voltage drop provided by any series drain resistor. Next I modified bias circuit with an additional feedback resistor from the drain to the gate. Measurements show that this circuit has lower bias variations in whole temperature range. Additional measurements of NF for three different circuits with PNP transistor, feedback resistor and strait bias were done. As expected there is no measurable difference in NF. Circuit with additional PNP transistor can exhibits instability in presence of large signal at the input. This is caused by high loop gain and can be suppressed by increasing value of decoupling capacitors. **Conclusion:** For LNA and medium power amplifier applications, even circuit without any temperature bias stabilization can be used over a wide temperature range. Circuit with one feedback resistor improves bias variations with temperature and more complicated circuit do not need to be used.

**Bias without feedback** (MGF1304a with  $R_d$  180 ohm and  $V_{dd}$  5V)

|                 |       |       |       |       |       |       |
|-----------------|-------|-------|-------|-------|-------|-------|
| Temperature [C] | -25   | 0     | 21    | 40    | 60    | 80    |
| Vds 2 [V]       | 2.00  | 1.99  | 1.98  | 1.97  | 1.95  | 1.91  |
| Id 2 [mA]       | 16.91 | 16.96 | 17.02 | 17.07 | 17.16 | 17.52 |

**With fb resistor** (FHX35LG  $R_d$  310 ohm,  $V_{dd}$  5V,  $R_f$  6.6k and  $R_{in}$  3.6k)

|                   |       |       |       |       |       |       |
|-------------------|-------|-------|-------|-------|-------|-------|
| Temperature [C]   | -25   | 0     | 21    | 40    | 60    | 80    |
| Vds1 compen. [V]  | 1.29  | 1.29  | 1.285 | 1.26  | 1.235 | 1.17  |
| Id 1 compen. [mA] | 12.21 | 12.21 | 12.22 | 12.31 | 12.38 | 12.60 |

**With fb resistor** (MGF1304a  $R_d$  180 ohm,  $V_{dd}$  = 5V,  $R_f$  6.6k and  $R_{in}$  4.5k)

|                   |       |       |       |       |       |       |
|-------------------|-------|-------|-------|-------|-------|-------|
| Temperature [C]   | -25   | 0     | 21    | 40    | 60    | 80    |
| Vds 2 compen. [V] | 1.94  | 1.99  | 1.99  | 1.99  | 2.01  | 1.90  |
| Id 2 comp. [mA]   | 16.97 | 16.98 | 17.00 | 17.06 | 17.11 | 17.22 |

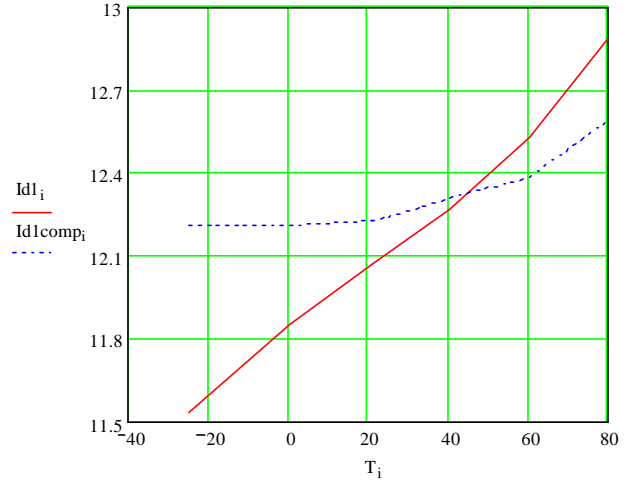

Fig

2. Drain current variations in temperature for LNA using FHX35LG

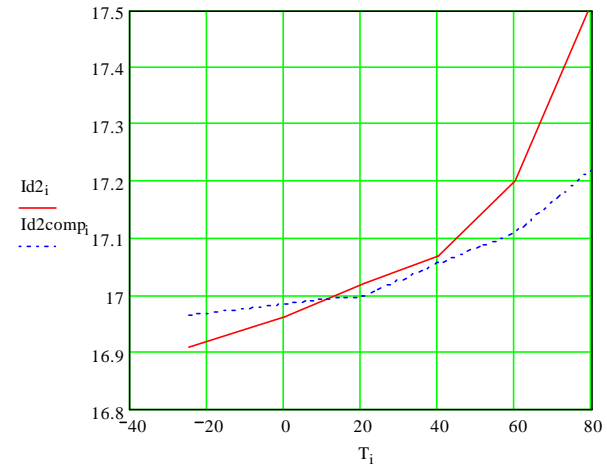

Fig 3.

Drain current variations in temperature for LNA using MGF1304a

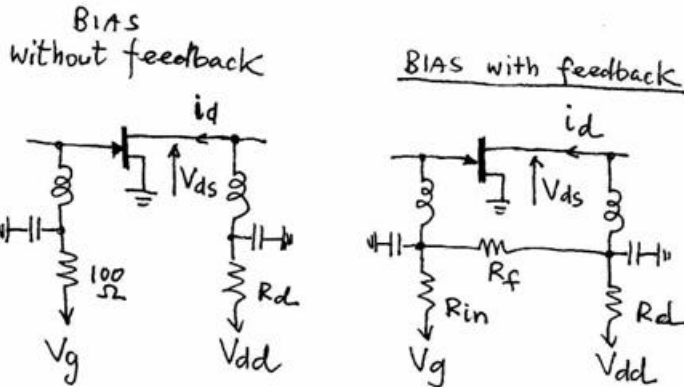

Fig.1. Schematics of the bias in test circuits

**Bias without feedback** (FHX35LG with  $R_d$  310 ohm and  $V_{dd}$  5V)

|                 |       |       |       |       |       |       |
|-----------------|-------|-------|-------|-------|-------|-------|
| Temperature [C] | -25   | 0     | 21    | 40    | 60    | 80    |
| Vds 1 [V]       | 1.47  | 1.39  | 1.31  | 1.26  | 1.18  | 1.08  |
| Id 1 [mA]       | 11.53 | 11.85 | 12.07 | 12.27 | 12.53 | 12.89 |

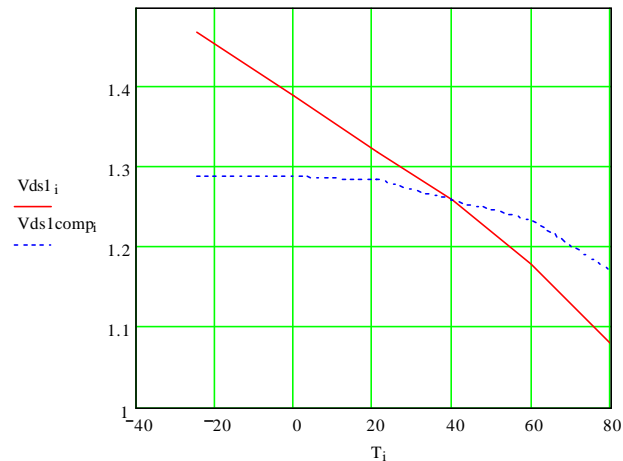

Fig 4. Drain voltage variations in temperature for LNA using FHX35LG

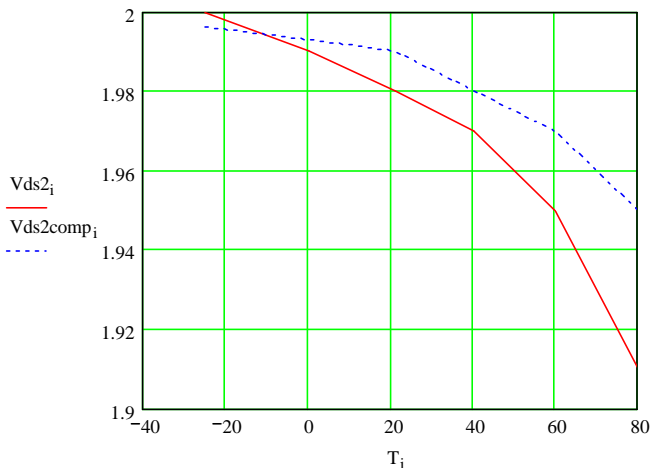

Fig 5. Drain voltage variations in temperature for LNA using MGF1304a

Additional measurements of NF for three different circuits with PNP transistor, feedback resistor and strait bias were done. As expected there is no measurable difference in NF. Circuit with additional PNP transistor can exhibits instability in presence of large signal at the input. This is caused by high loop gain and can be suppressed by increasing value of decoupling capacitors. **Conclusion:** For LNA and medium power amplifier applications, even circuit without any temperature bias stabilization can be used over a wide temperature range. Circuit with one feedback resistor improves bias variations with temperature and more complicated circuit do not need to be used.

**FINAL:** I sorry to report that K9BCT/4's wife passed away recently. It was not unexpected, but will certainly change his life. Randy saved the C6ARI dxpedition by providing preamps after the preamps planned for the dxpedition failed during testing prior to setting sail.

I have changed plans for my Hawaii dxpedition and am now gathering gear for operation on 70 cm rather than 23 cm and am looking for a higher power solid state amplifier I can use on the island.

That's the story for this month. I plan to be active in the Eur Digi Contest and also on for 8N1EME. Please note that the Eur EME (DUBUS/REF) Contest rules have been some important change. Hope to CU all off the moon. 73, AI - K2UYH

**EUROPEAN EME CONTEST 2007**  
Sponsored by DUBUS and REF

The European EME contest is intended to encourage world-wide activity on moonbounce. Each different call prefix forms a Multiplier.

**1. Contest Dates & Bands:**

|                       |  |                  |
|-----------------------|--|------------------|
| <b>First weekend</b>  | <b>February 24/25</b>                  | <b>00 - - 24</b> |
| UTC                   | 50, 144, 432 & 1296 MHz - Digital only |                  |
| <b>Second weekend</b> | <b>March 24/25</b>                     | <b>00 - - 24</b> |
| UTC                   | 432 MHz and 5.7 GHz and up CW/SSB      |                  |
| <b>Third weekend</b>  | <b>April 21/22</b>                     |                  |
| 00 - - 24 UTC         | 144 MHz and 2.3 / 3.4 GHz CW/SSB       |                  |
| <b>Fourth weekend</b> | <b>May 19/20</b>                       |                  |
| 00 - - 24 UTC         | 1296 MHz CW/SSB                        |                  |

**2. Sections and Awards:**

|             |         |             |        |
|-------------|---------|-------------|--------|
| <b>QRP</b>  | 144MHz  | <100kW EIRP | 432MHz |
| <400kW EIRP | 1296MHz | <600kW EIRP |        |

but no separate QRP/QRO categories

**QRO** On 144, 432 and 1296, stations with EIRP equal to or > than stated above.

**PRO** Non-amateur equip. or ant. PRO stations will have scores listed separately.

**CW/SSB** All QSOs in CW and/or SSB mode - no other modes used.

**DIG** All QSOs in digital mode (e.g. all the "JT" modes) - no other modes used.

**MULTI** Multi-OP is >1 OP - but no separate category. Multi-operator and QRO stations will be highlighted in the general classifications. All QRP/QRO band winners and QRP/QRO multi-band winners will receive a year's free subscription to DUBUS magazine. The multi-band section contains weekend 2, 3 and 4 only. In each band/section certificates will be sent to ALL entries

**3. Rules:**

3.1 For the purpose of the contest only one scoring per valid QSO with the same station can be logged in each band.

3.2 During the European EME Contest dates & times, communication via the Earth-Moon-Earth path is the only type of communication permitted by participants and stations worked.

Therefore during Contest time, participants are not allowed to use other communications medium such as internet or packet radio, to make skeds, announce their CQ frequency, spot other stations, exchange any QSO progress info, confirm in real time whether the QSO was valid or not.

3.3 When the moon is not visible to participants, public comments on QSO accomplishments and moon conditions are permitted.

3.4 Stations participating in the Microwave bands (2.3 GHz and above) are permitted to announce their time plan of proposed band segment activity, during times when they have no moon visibility.

3.5 Stations deviating from the rules are not eligible to submit logs for the European EME Contest.

**4. Contest Exchange:**

For a valid EME QSO, both stations must have copied all of the following:

4.1 Both callsigns from the other station

4.2 Signal report from the other station (using TMO procedure or RST)

4.3 R, from the other station, to acknowledge complete copy of 4.1 & 4.2

**5. Logs:**

Logs must be separate for each band, and should be in normal "logbook" format. Top line: Your callsign, Band, Each QSO: Date/time, Callsign, Report sent, Report received, Points, Multiplier

Bottom line: Total points, Total multipliers, Total claimed score.

Note: For WSJT Digital EME QSOs signal levels of stations worked, must be included in the log.

**6. QSO Points:**

6.1 CW/SSB:

100 points for each random QSO completed.

10 (ten) points for each sked QSO completed on 144/432/1296MHz.

100 points for each random or sked QSO completed on 2.3GHz or higher bands.

6.2 DIGITAL:

100 points for each random QSO completed at signal levels up to -25db.

10 (ten) points for each sked QSO, as well as QSOs at signal levels exceeding -25 dB, except if the necessary information has been displayed properly in the average display.

**7. Multipliers:**

Each different call prefix is a multiplier (e.g. DL1, DK9, SM2, S51, S54, G6, KM5, W5, JA6, VK4, WA6, K6, PA1, PE1, etc). See example of WPX Contest rules for further details on prefix multipliers.

**8. Total Scores:**

Single band score = [Total of QSO points] \* [Total of multipliers].

There will be one QRP winner and one QRO winner on each band.

Multiband score = [(Total sum of points on 144-1296MHz) + (2 \* total sum of points on 2.3GHz or above)] \* [Total sum of multipliers on all bands] There will be one QRP multiband winner and one QRO multiband winner. Multiband stations will also be listed as an entry on each separate band worked, and can also win single-band awards.

**9. Contest Entries:**

Copy of the log for each band with details of points, multipliers and total points.

The following information **MUST** also be included for each band: 1. Output power, transmit cable loss, antenna type and gain. 2. Categories: QRO/QRP - single/multi operator - CW/SSB - DIG 3. Name(s) of all operators 4. Grid locator. Other info is welcome: Comments, conditions, station details, photographs, etc.

Note: For WSJT Digital EME QSOs signal levels of stations worked, must be included in the log.

**10. Sending Your Entry:**

Contest entries **MUST** be sent no later than 28 days after the end of the last contest weekend (i.e. in the mail or e-mail by 19 JUNE 2007). Entries for the **FIRST weekend (Digital)** must be send no later than 28 days after February 25th (i.e. in the mail by 23rd March 2007). Mail address: Patrick Magnin, F6HYE, Marcorens, F-74140 BALLAISON, France. You can also e-mail your contest entry in ASCII format to: [info@dubus.de](mailto:info@dubus.de) or [DUBUS@web.de](mailto:DUBUS@web.de). All email entries will be acknowledged within one week. For further questions contact: [info@dubus.de](mailto:info@dubus.de)

Good Luck in the Contest!

For REF: Patrick Magnin, F6HYE

For DUBUS: Joachim Kraft, DL8HCZ/CT1HZE

Referee: Dimitris Vitorakis, SV1BTR